



# InstruFiber

INSTRUMENTAÇÃO E FIBRA ÓPTICA

## HD 2015

- ▶ [ GB ] Tipping bucket rain gauge



**[ GB ] Description**

The HD2015 is a reliable and sturdy bucket rain gauge, entirely constructed of corrosion resistant materials in order to guarantee its durability. To ensure accurate measurements even with low temperature climatic conditions or during and after precipitations of snow, a version with heating system, automatically activated around +4 °C, has been developed to prevent snow deposits and ice formations.

The rain gauge is formed by a metal base on which a tipping bucket is set. The rain collector cone, fixed to the aluminium cylinder, channels the water inside the tipping bucket: once the predefined level is reached, the calibrated bucket rotates under the action of its own weight, discharging the water. During the rotation phase, the normally closed reed contact opens for a fraction of a second, sending an impulse to the counter.

The quantity of rainfall measured is based on the count of the number of times the bucket is emptied: the reed contacts, normally closed, open at the moment of the rotation between one bucket's section and the other. The number of impulses can be detected and recorded by a data logger such as the **HD2013-DB** or by a pulse counter.

A removable filter for periodic cleaning and maintenance is inserted in the water collector cone so as to prevent leaves or other elements blocking the end of the hole. For a better water flow, the collecting cone is treated with a non-stick coating.

The version with heating option **HD2015R** works with 12 Vdc or 24 Vdc direct voltage (to be specified at the time of order) and absorbs about 50 W. The heating system is activated around +4 °C.

**When submitting your order**, it is possible to request a bird dissuader, made of eight 3 mm diameter spikes, 60 mm in height, to be installed on the rain gauge.

**Technical characteristics**

	HD2015R	HD2015
Power supply	12 Vdc or 24 Vdc ± 10% / 50 W (to be specified at the time of order)	---
Type of output contact	NC contact (opens during tipping)	
Resolution	0.1 - 0.2 or 0.5 mm/tip <b>to be specified at the time of placing the order</b>	
Accuracy	See the typical <b>normalized</b> curve in fig. 1. The curve is normalized to the resolution 0.200 mm/tip @ 50 mm/h. If the HD2013-DB data logger is used, the measurement can be automatically corrected according to the curve.	
Operating temperature range	-20 °C ...+60 °C	+4 °C ...+60 °C
Heating intervention temperature	+4 °C	---
Protection degree	IP 64	
Collector area	200 cm <sup>2</sup>	
Minimum section of the wires of the connecting cable	0.5 mm <sup>2</sup> for the version without heating system (HD2015) 2.5 mm <sup>2</sup> for the version with heating system (HD2015R)	

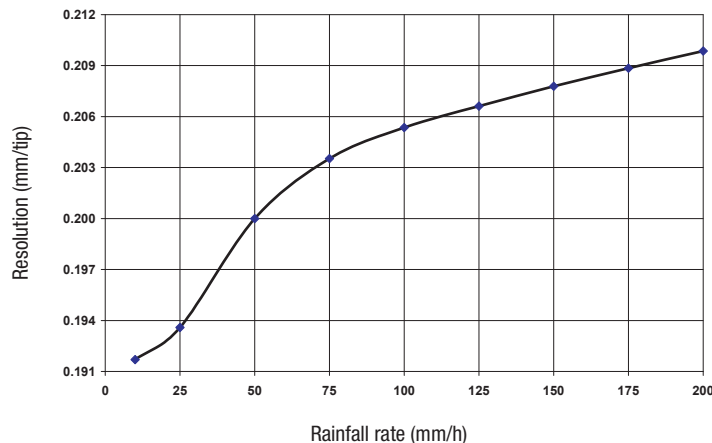

**Fig. 1 - Resolution as a function of the rainfall rate**

**Installation and maintenance**

The rain gauge is supplied already calibrated at 0.1 - 0.2 or 0.5 mm of rain per tip of the bucket: the calibration value is shown on the instrument label.

The instrument must be installed in an open area, away from buildings, trees, etc., ensuring that the space above is free from objects which may obstruct the rain measurements and placed in an easily accessible position for periodical cleaning of the filter.

Avoid installations in areas exposed to wind gusts, turbulences (for example on the top of a hill) as they may distort the measurements.

The rain gauge can be installed on the ground or 500 mm off the ground. Other sizes of the support for installation off the ground are available upon request.

For the installation on the floor, three adjustable support feet are supplied, so that the instrument can be levelled correctly, and also proper holes for a possible fixing on a floor.

For installations off the ground, a flange to be fixed to the base of the instrument, where the support clamp must be inserted, is supplied; the clamp ends either with a flange so that it can be fixed to the floor, or with a tip to be driven into the ground. For the various fastening systems please refer to the figures 5, 6, 7 and 8.

In order to make the tipping device properly working and the measurements correct, it is important that the instrument is placed perfectly levelled. The base of the rain gauge is fitted with a bubble level.

For the installation, unscrew the three screws from the base of the cylinder that supports the water collector cone (see fig. 2). A heating resistor is placed around the cone in the **HD2015R** version. The heater is automatically disconnected when the cone is lifted up.

**Electrical connection**

For the version without heating system, use a 2-wire cable with 0.5 mm<sup>2</sup> minimum wires section; for the version with heating system, use a 4-wire cable with 2.5 mm<sup>2</sup> minimum wires section. Use a shielded cable over long distances. Slide the cable through the cable gland and fasten it with the cable fastener located near the entry hole, at the base of the rain gauge. Unscrew the terminal block protection cover and perform the connections as shown in figure 2. **The rain gauge output, indicated in point 1 of the drawing below, must be connected to the input of the HD2013-DB rain gauge data logger (please see the details in the manual of the data logger) or to a pulse counter or to a data logger.**

The heated version requires power for the resistors (12 Vdc or 24 Vdc depending on the version supplied): perform the connection as indicated at point 2 of fig. 2.

If the connections are correctly set, the LED placed near the terminals will be lit up.

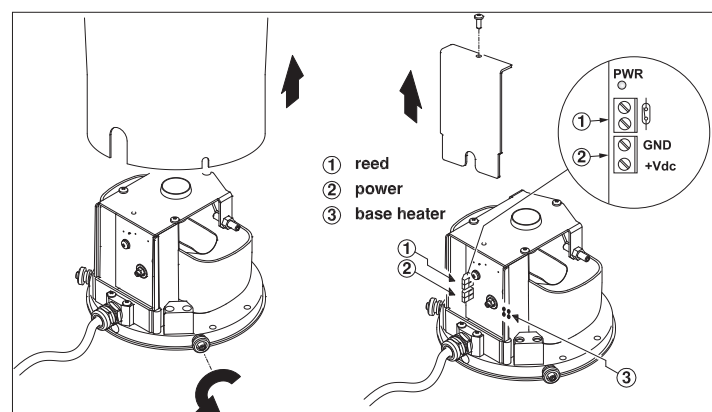

**Fig. 2 - Electrical connections (version with heating system)**

### Tipping bucket

The tipping bucket is locked during the transport of the rain gauge. To unlock the bucket, remove the holders as shown in fig. 3 here below.

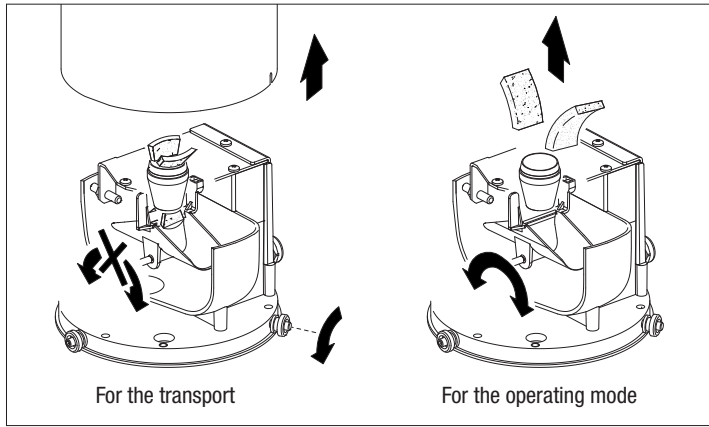

Fig. 3 - Locking and unlocking the tipping bucket

The oscillation of the tipping bucket can be adjusted through the two threaded rods located at the sides of the bucket, as illustrated in fig. 4.

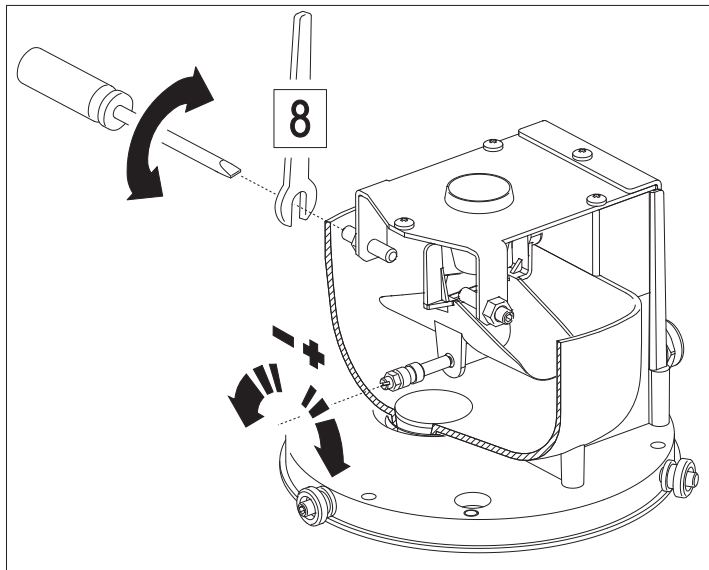

Fig. 4 - Adjustment of the tipping bucket

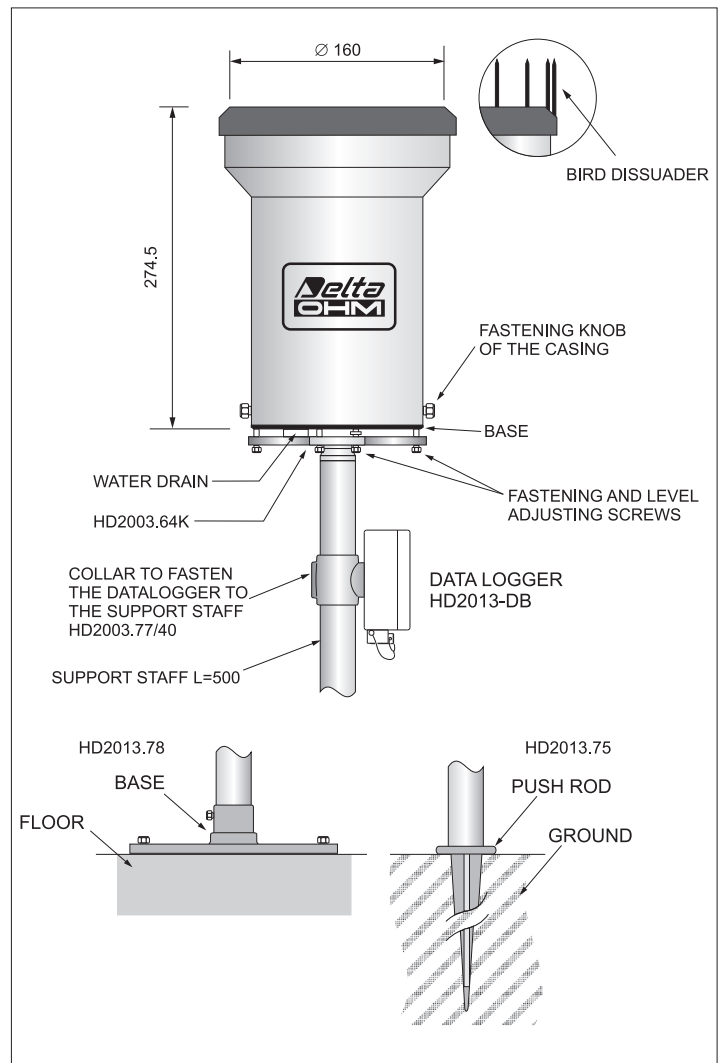

Fig. 5 - Mechanical dimensions, installation modes

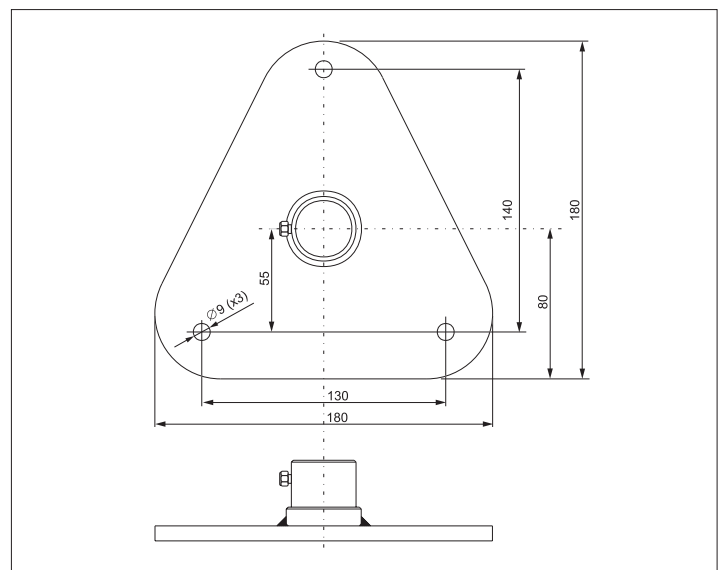

Fig. 6 - Base for installation on the floor (HD2013.78)



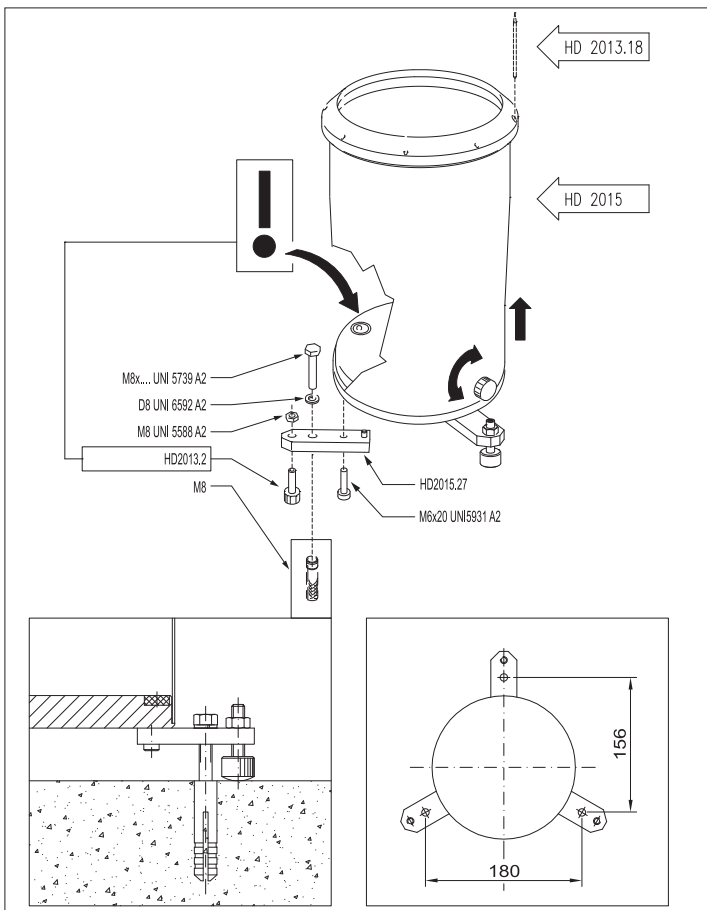

Fig. 7 - Installation on the floor

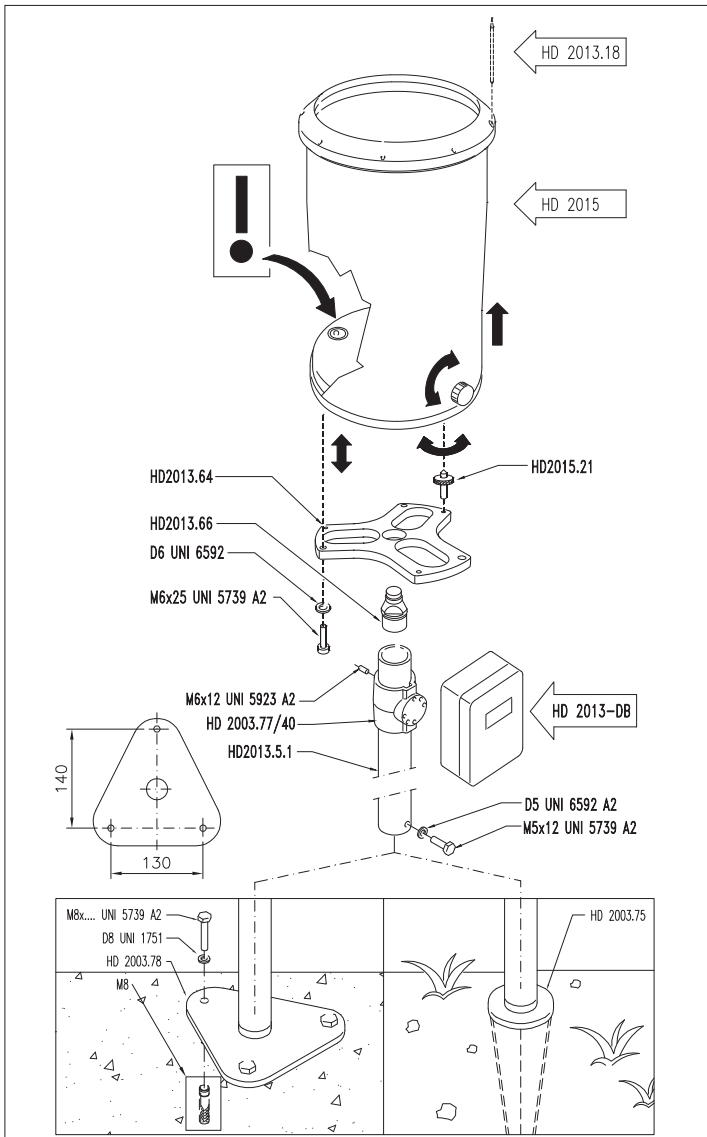

Fig. 8 - Installation off the ground

### Maintenance

Verify periodically the cleanliness status of the filter; check that there is no presence of debris, leaves, dirt in the lower filter or anything else that might obstruct the flowing of water. Check that the tipping bucket contains no deposits of dirt, sand or any other obstruction. If necessary, the surfaces can be cleaned with non aggressive detergents.

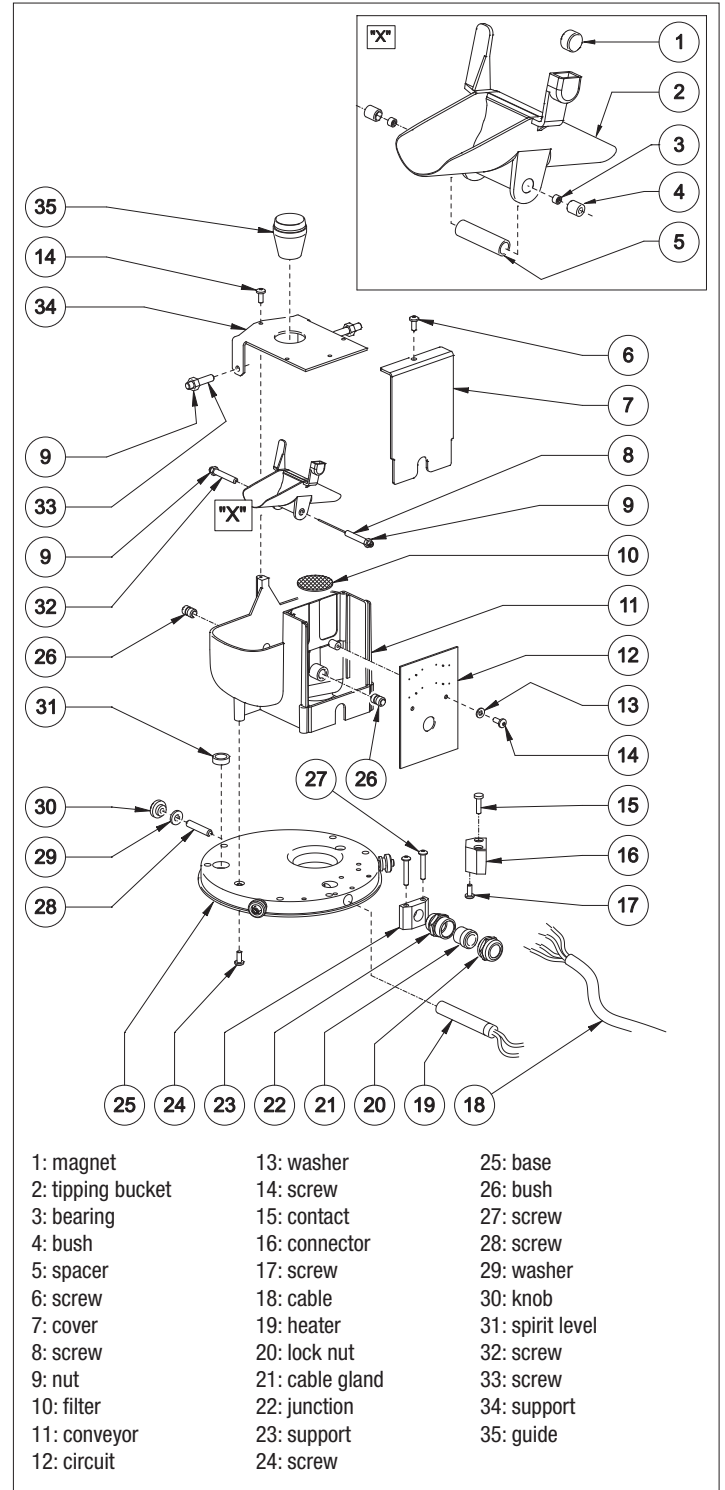

Fig. 9 - Exploded view of the lower part (version with heating system)

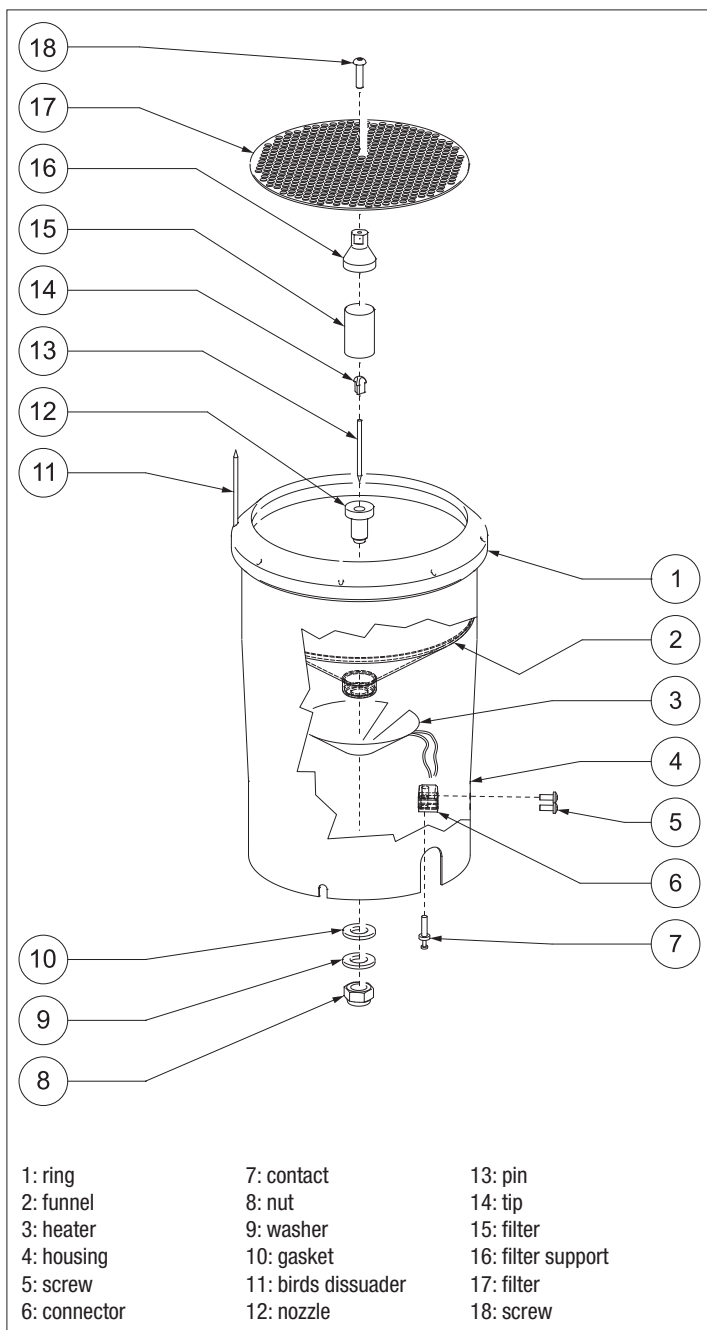
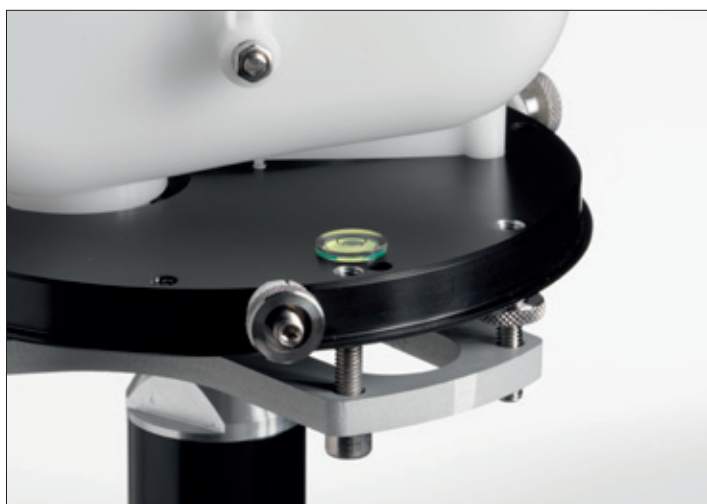

Fig. 10 - Exploded view of the upper part (version with heating system)



Detail of the bubble level

#### PURCHASING CODES

**HD2015:** Tipping bucket rain gauge, area 200 cm<sup>2</sup>, for temperatures from +4 °C to +60 °C. **Resolution to be specified upon request at the time of placing the order:** 0.1 - 0.2 or 0.5 mm. Output contact normally closed.

**HD2015R:** Tipping bucket rain gauge, area 200 cm<sup>2</sup>, with heating system for temperatures from -20 °C to +60 °C. **Resolution to be specified upon request at the time of placing the order:** 0.1 - 0.2 or 0.5 mm. Output contact normally closed. Power supply voltage: 12 Vdc or 24 Vdc ± 10% (to be specified at the time of placing the order) / absorbed power 50 W.

**HD2013.18:** Bird dissuader.

**HD2013.5K:** Kit of accessories for the installation of the rain gauge raised 500 mm off the ground. Anodized aluminum support staff L=500 mm.

**HD2013.5K1:** Kit of accessories for the installation of the rain gauge raised 1 m off the ground. Anodized aluminum support staff L=1 m.

**HD2013.5K2:** Kit of accessories for the installation of the rain gauge raised 2 m off the ground. Anodized aluminum support staff L=2 m, accessories HD2003.75K for bracing the mast for installation with pegs on the ground.

**HD2013.5K3:** Kit of accessories for the installation of the rain gauge raised 2 m off the ground. Anodized aluminum support staff L=2 m, accessories HD2003.78K for bracing the mast for installation on the floor.

**HD2013.64K:** Kit of accessories for securing the rain gauge on the top of the mast; it allows the levelling. To combine with the mast L=500mm, 1m or 2m.

**HD2013.75:** Base with tip for the ground to support the rain gauge installed off the ground (to combine with the kit of accessories HD2013.5K...).

**HD2013.78:** Flat base for fastening the support of the rain gauge raised above ground (to combine with the kit of accessories HD2013.5K...).

**HD2013-DB:** Rain gauge data logger. With backlit LCD. Detects and stores up to 32.255 pulses produced by the bucket emptying. Resolution configurable from 0.050 to 1.599 mm/pulse. Isolated RS232 serial output. IP 67 protection degree. Powered by a 3.6 V lithium battery. Supplied with: internal not rechargeable lithium-thionyl chloride (Li-SOCl<sub>2</sub>) battery (BAT-2013DB), HD32MTLogger software, 4-pole M12 female connector (FCM12.4).

**HD2013.77/40:** Clamping for fixing the data logger to the Ø 40 mm support staff of the rain gauge.

The use of two cross-connected clampings allows the fixing of a transverse mast for the installation of other sensors (e.g. solar radiation sensors, etc.).





# InstruFiber

INSTRUMENTAÇÃO E FIBRA ÓPTICA

11 4172-0606

11 4386-0362

Manufacture of portable, bench top and process scientific instruments  
Current and voltage loop transmitters and regulators  
Temperature - Humidity, Dew point - Pressure - CO, CO<sub>2</sub>  
Air speed - Light - Optical Radiation  
Acoustics - Vibration  
Data logger - Data logger wireless  
Microclimate  
pH - Conductivity - Dissolved Oxygen - Turbidity  
Elements for weather stations



LAT N° 124 Signatory of EA, IAF and ILAC Mutual Recognition Agreements  
Temperature - Humidity - Pressure - Air speed  
Photometry/Radiometry - Acoustics

#### CE CONFORMITY

- **Safety:** EN61000-4-2, EN61010-1 Level 3
- **Electrostatic discharge:** EN61000-4-2 Level 3
- **Electric fast transients:** EN61000-4-4 Level 3, EN61000-4-5 Level 3
- **Voltage variations:** EN61000-4-11
- **Electromagnetic interference susceptibility:** IEC1000-4-3
- **Electromagnetic interference emission:** EN55022 class B



**Delta**  
**OHM**